

Team BangaloreRobotics

LASSIE – An Autonomous Underwater Vehicle for Robosub 2013 competition.

Dr. G Venkatesh, Vishnu Veilu Muthu (leader), Srinivas Sadgun, Gargi Kapali, Hridya B R, Vijetha Aithal K S, Navyatha H S, Mahendran Muthukumar, Niranjan Dinesh

Abstract – LASSIE was developed in 2013 at the Bangalore Robotics center for the Robosub 2013 Competition. The AUV incorporates key advancements and innovations to make it agile and cheap. It is light weight weighing only about 16 Kgs and has a small footprint of L*W*H 0.6*0.50*.04 m. All of the AUV's wiring resides within having no contact with the water making it robust and reliable. Lassie is powered by 4x 5Ah Lithium polymer battery. The AUV structure and program control system are discussed in the paper.

I. Introduction

The "Team BangaloreRobotics", a multi-disciplinary and a multi-University team from Bangalore working together at the Bangalore Robotics center since Jan' 2013 has developed the AUV Lassie for the Robosub 2013 competition. The competition is held in July at the TRANSDEC facility, part of SPAWAR Systems Center Pacific in San Diego, California. The competition is designed to challenge the AUV's with tasks that simulate real-world missions. These include visual and acoustic detection of identified element, obstacle avoidance and navigation. The elements to be identified range from different shapes, color recognition and torpedo firing. These tasks are to be completed by the

AUV autonomously without any human control or interaction.

II. Design Overview.

The AUV was designed with the main objective of making it as light weight and agile as possible. Hence a simple cube design was chosen for the hull structure. The vehicle's approximate dry weight is 16Kgs and it measures 60 cms in length, 50 cms in width and ?? cms in height. Lassie features a single hull with integrated camera and all control electronics. It is powered by 4 Crust Crawler thrusters which provide it 4 degrees of freedom. The vehicle incorporates the COTS Arducopter APM2.5 board that provides the autopilot for the vehicle. This board incorporates a variety of sensor on-board and has the possibility to incorporate external sensors for greater fine-grained control. The vehicle is powered by 4 x 5Ah Lipo batteries The vehicle's software is run-onboard with a dual core Intel Atom processor. The software is built upon Matlab and Roborealms libraries.

III. Mechanical Systems

A. The Hull

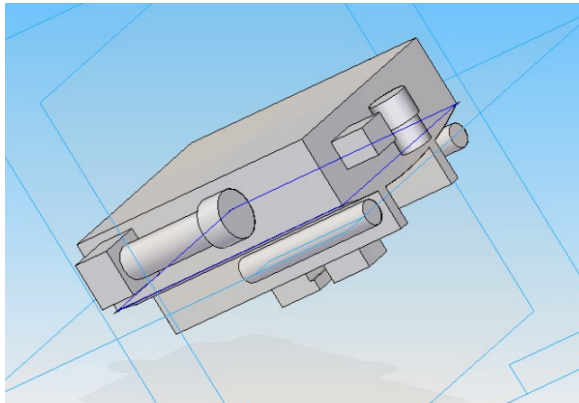

The Hull was designed with main objective of making the AUV as light as possible. Hence a simple cube design was opted for the Hull structure with the measurements approximately being 60*50*8.5 cm.

The material for the Hull was also chosen based on the density and strength. The materials that were chosen for the design were Polycarbonate Safeguard UVX, Acrylic, Polypropylene

Material	Density ¹
Polycarbonate Safeguard UVX	1.20 g/cm ³
Acrylic	1.20 g/cm ³
Polypropylene Uniboard Standard	0.65g/cm ³

¹ Density is calculated by dividing the mass of the material by the volume and is normally expressed in g/cm³. Specific Gravity (SG) is defined as the ratio of density of the material to the density of water (1 g/cm³) at a specified temperature. Material with Specific Gravity less than 1 means that the material will float in the water.

Considering all the characteristics, Polypropylene Uniboard Standard was chosen. The material chosen is water proof and hence all the electronic components are arranged in the Hull.

The Hull accommodates 2 batteries, Motherboard (Toradex) + SSD, Arduino board, Ardupilot-IMU.

B. Torpedo Launcher and Marker Dropper

With the theme of Wire-free design, the Torpedo Launcher and Marker dropper are similar.

This is an electro-mechanical design common for both the functions.

The DC motor driven Torpedo is held captive by magnets and are deployed by changing the magnetic poles. The motor is triggered by a magnetic reed switch, which simply connects the inbuilt power to the motor. The motor is ON for a timed duration, not exceeding the distance to be travelled.

C. Grabber

The Grabber is an Expandable Leg design. The Leg is expanded by a Motor driven screw rod. The technique is to trap the wreath by expanding the lower extremity of the Leg outwards at an angle of 120 deg.. The release is when the Leg is contracted to a vertical angle.

D. Thrusters

Propulsion is provided by four brushless motor commercial off-the-shelf (COTS) thrusters. Two thrusters are oriented in each of the vehicle's main axes. The thrusters are all CrustCrawler 400HFS-L UROV/ ROV. This mounting scheme

provides the vehicle with Linear control, as well as Pitch and Yaw.

The Roll control was eliminated by making the structure stable for self-righting the AUV. This was decided on to minimize the motors and drivers, and hence, to minimize the Power budget of the system.

IV. Sensors

A. Camera

The vehicle has 2 CAM's onboard. 2 camera types were chosen – Foscam 1818 wireless IP camera type. The cameras were dismantled and the Pan-Tilt mechanisms were discarded, as they were unnecessary for this application.

The Network camera is wired to the Motherboard Inside the Hull.

B. Acoustic Processing

The Pinger detection system consists of a self designed array of Hydrophones using water proof transducers. The Transducers are connected to the GPIO of the Motherboard for processing.

The software is coded to sample and hold the received 20Khz-4-KHZ signal. The software sub-routine then aligns the AUV towards the maximum signal direction.

Functional Block Diagram

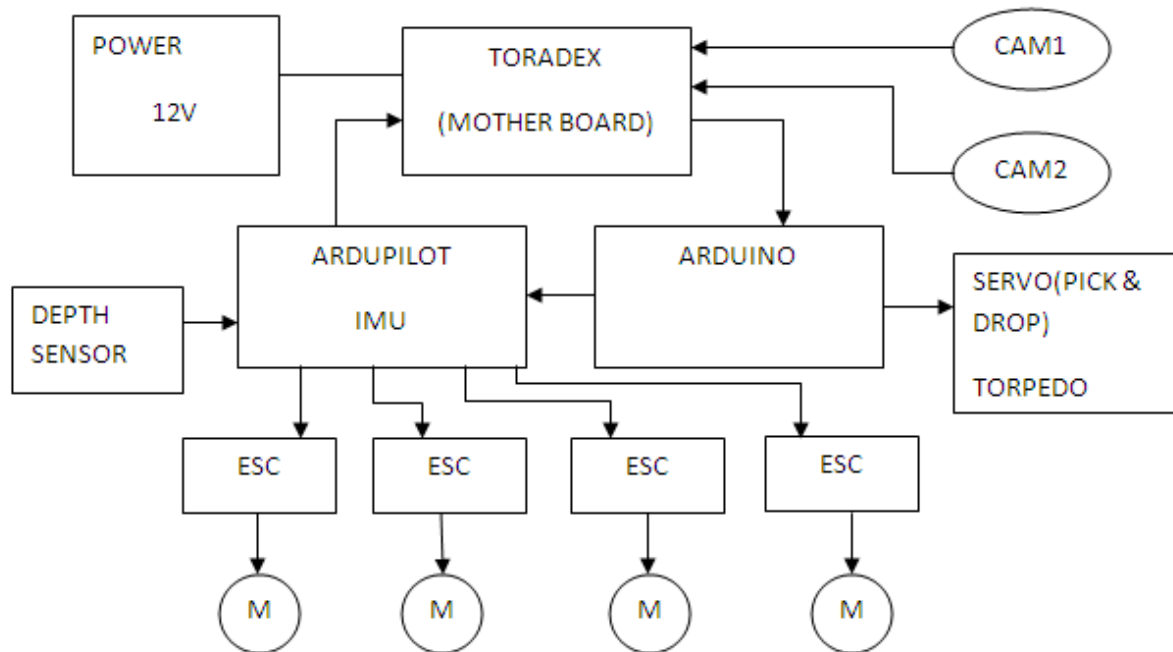

Block diagram

C. Depth Measurement

The depth measurement is through the Baro-Sensor on the IMU. This is

basically an Altimeter but is used to measure the Hull pressure. The Sensor outputs are calibrated to indicate depth in feet.

Depth data is used as a waypoint info and is correlated with the Magnetometer data of the IMU. Together, they indicate a fairly accurate position of the AUV in the competition scene.

The vehicle has an Arducopter APM2.5 auto-piloting module. This board hosts a pressure sensor, Gyro and an accelerometer. There is a depth sensor integrated externally to the ardupilot module. The auto-piloting system is controlled from an Arduino board through the Matlab/Roborealms softwares. The arduino board additionally controls the grabber and the torpedo systems onboard. The thrusters are controlled directly by the ardupilot.

The onboard thrusters are controlled by the ardu-pilot. They are powered locally through H-bridge configuration.

V. Software

All high level functionality including the mission tasks are achieved via the vehicles software system. The systems

software is built around Windows 7 operating system and the image processing softwares Matlab and Roborealms. The Ardupilot auto-piloting module is controlled from an Arduino based platform.

The Open-source code is modified for AUV functionality. This being different from in –the-air machines with respect to linear speed, reaction time and Motor RPM.

Vision Processing

Roborealms is an application for use in vision, image analysis and robotic vision

systems. There are two CAM's onboard the vehicle. The data from the same are processed by Matlab and Roborealms which then control the auto-piloting system of the vehicle. Matlab and Roborealms process the images from the camera simultaneously.

Based on a selection criteria output from one of the systems and the sensor information recorded by the APM board the vehicles navigation and task system is controlled.

The AVM Navigator module in Roborealms is tasked with the vehicles object recognition. Apart from this the module offers Navigation capabilities based on the object being tracked.

VI. Computer

The software on the vehicle is powered by an Intel Atom Z-530 processor running at 1.6Ghz. The Robin Z530L embedded Nano COM express computer on module along with a 64GB solid state drive (SSD) is used.

System Mother board



Robin Z530 L is an embedded Nano COM Express™ computer on module designed for high performance computing with low power consumption. The Robin Z530 L is based on the Intel® Atom™ Z530 ('Silverthorne') processor, running at 1.6GHz, and the Intel® System Controller

Image Processing:

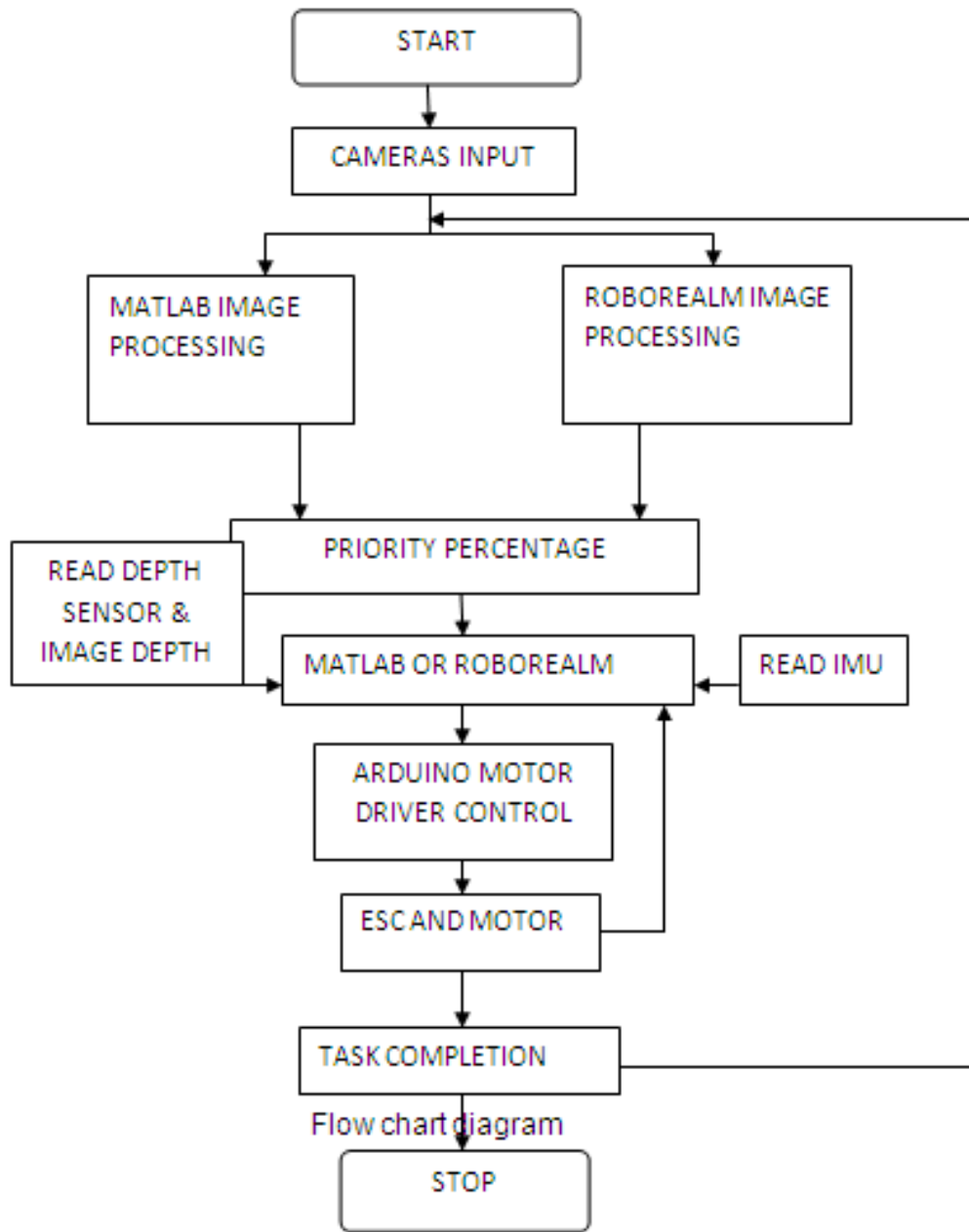

VII.

Toradex Atom Robin Z530 L

Robin Z530 offers a single PCI Express x1 lane, GLAN, HDA and up to 7 High Speed USB ports for fast signal



connectivity. One USB port can be configured as USB client. In standard configuration, it features dual independent graphical outputs with VGA and LVDS. is an embedded Nano COM Express™ computer on module designed for high performance computing with low power consumption. The Robin Z530 L is Hub US15W and features 1GByte DDR2 RAM.

Connectivity and Storage



based on the Intel® Atom™ Z530 ('Silverthorne') processor, running at 1.6GHz, and the Intel® System Controller

Robin Z530 offers a single PCI Express x1 lane, GLAN, HDA and up to 7 High Speed USB ports for fast signal connectivity. One USB port can be configured as USB client. In standard configuration, it features dual independent graphical outputs with VGA and LVDS.

The IMU Sensors Over view

The ArduPilotMega 2.5 system features a newly designed enclosure and an optional Power Module with integrated 5.3V regulator and current and voltage sensing.

The ArduPilot Mega 2.5 is a complete open source autopilot system and the bestselling

The Board is a Atmega2560 based system, with built in 3 Axis Accelerometer, Gyroscope, Magnetometer and Barometer.

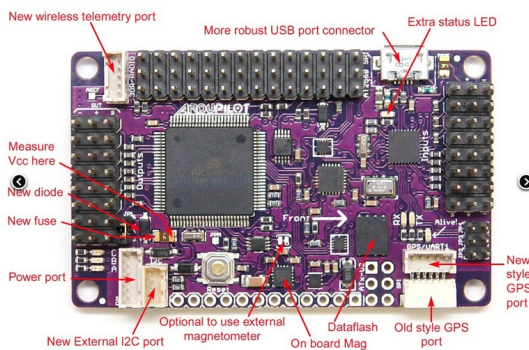

Thruster Motor

400HFS-L UROV/ ROV Thruster

2.36"(60mm)", 4 blade, brass propeller mated with a aluminum propeller adapter generates 15 pounds of thrust from 24 to 50 volts

16th AUVSI ROBOSUB student Competition 2013

Propeller is efficient in both forward and reverse thrust

Type II hard anodized finish for maximum corrosion resistance in salt and fresh water

Rugged 6061 aluminum thruster housing technology 300ft (100m) depth rating



Powerful 400W brushless motor with a 4.28:1 gear ratio .

Four Motors are used , 2 for up/down and Oith, 2 for Linear movement and YAW.

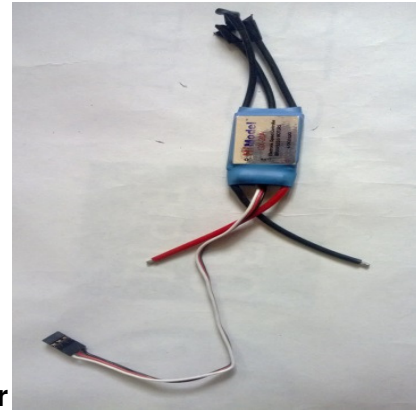

Motor Controller

The Brushless DC motros are controlled by 30A 12V Electronic Speed controllers.

The Controllers run a bit warm but are suffient to drive the motors to peak RPM.

Conclusion

The AUV is a first design and competition effort of Team BangaloreRobotics.

The Design was evaluated mainly for Three major parameters:

1. Small dimension
2. Redundant Analysis and Control system
3. Light weight

- ✓ The emphasis was in Low Power consumption and energy efficiency.
- ✓ A lighter AUV needs a low power budget.
- ✓ The Mission time of useful deployment is comparatively longer.
- ✓ An attempt was made to construct a lighter AUV.
- ✓ Limited time and budget constraints have limited the number of innovative ideas to a lower number than was desired.
- ✓ A major part of the Design was the Mechanical and structural variations.

The Team is thankful To AUVSI Foundation and ONR for providing this opportunity to be a part of the ROBOSUB competition 2013.

- Mentor
- Team Captain

16th AUVSI ROBOSUB student Competition 2013

BANGALOREROBOTICS

The Team.

GURAPPA	VENKATESH	Team Mentor, Faculty Advisor	BANGALORE INDIA	BANGALORE ROBOTICS
ARUL	VISHWANATHAN	Team Advisor	BANGALORE INDIA	NOKIA-SIEMENS
SHRENIK	DEVASANI	Tech Advisor	BANGALORE,INDIA	AMAZON INC.
VISHNU	VEILU MUTHU	Captain	VIRUDHUNAGAR INDIA	ANNA UNIV,
DEVANAHALLI SHASHIKUMAR	SADGUN SRINIVAS		BANGALORE INDIA	ILLINOS univ
KAPALI	GARGI	Instrumentation Engg	BANGALORE INDIA	MSRIT, VTU
HRIDYA	BINDIGANAVALA RAMESH	Instrumentation Engg	MYSORE INDIA	MSRIT, VTU
AITHAL	VIJETHA KOTA SURESH	Instrumentation Engg	DAVANGERE INDIA	MSRIT, VTU
SATHYA PRASAD	NAVYATHA HONISIGERE	Instrumentation Engg	MYSORE INDIA	MSRIT, VTU
DONTHI	NAGENDRA BABU RAJU		CHITTOOR INDIA	RHEIN-WAAL UNIV
MUTHUKUMAR	MAHENDRAN		VIRUDHUNAGAR INDIA	ANNA UNIV.
NIRANJAN	DINESH		BANGALORE INDIA	N. VIRGINIA community College

Web: <http://auvsi.bangalorerobotics.in/2013/index.htm>

